

MEMS MICROPHONE ON BREAKOUTBOARD

COM-MIC-ADMP401

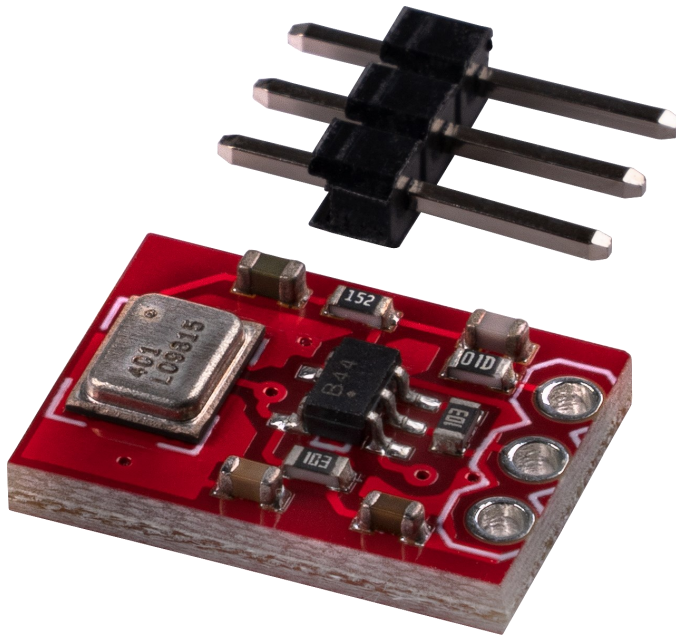

1. GENERAL INFORMATION

Dear customer,

thank you very much for choosing our product.
In the following, we will introduce you to what to observe while starting up and using this product.

Should you encounter any unexpected problems during use, please do not hesitate to contact us.

2. USAGE WITH THE RASPBERRY PI



This guide was written under Raspberry Pi OS Bookworm for the Raspberry Pi 4 and 5. It has not been checked with newer operating systems or hardware.

This is an analog sensor.

Since the Raspberry Pi has no analog inputs, you have to use an analog-to-digital converter. In this example we use the ADC [COM-KY053](#) from [Joy-IT](#).

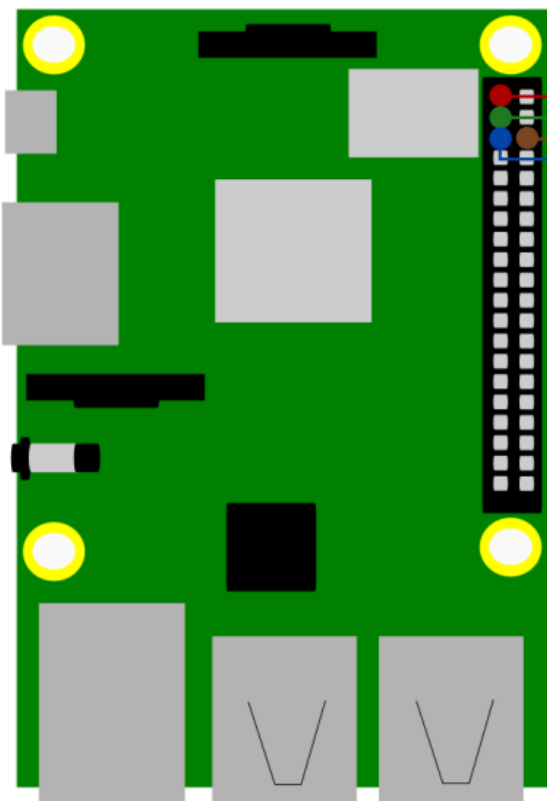

Raspberry Pi	KY-053	ADMP401
Pin 1 (3.3 V)	VDD	VCC
Pin 6 (Ground)	GND	GND
Pin 2 GPIO 2 (SDA)	SDA	-
Pin 5 GPIO 3 (SCL)	SCL	-
-	A0	AUD

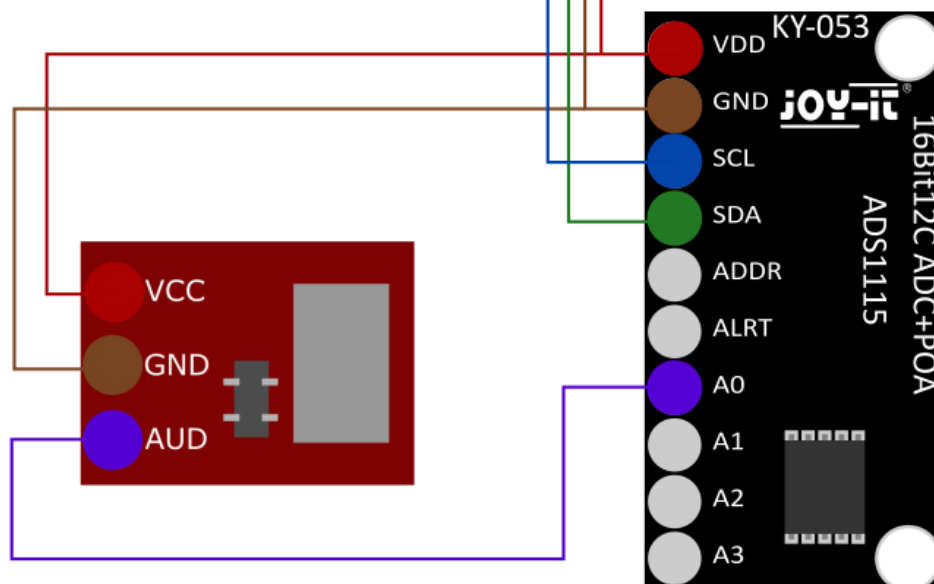

First you need to enable I2C on your Raspberry Pi. To open the configuration, enter the following command:

```
sudo raspi-config
```

There select **3 Interface Options → I4 I2C** and enable the I2C interface.

You have now successfully activated I2C. The analog-to-digital converter is now accessible under the I2C address 0x48, which is set by default for this sensor. The I2C address will be different if you have already configured it before configuring your Raspberry Pi.

Now install pip3 with the following command:

```
sudo apt-get install python3-pip
```

The next step is to set up the virtual environment. To do this, enter the following commands:

```
mkdir project-name
```

```
cd project-name
```

```
python -m venv --system-site-packages env
```

```
source env/bin/activate
```

We use the [Adafruit CircuitPython ADS1x15](#) library for our code example, which is released under the [MIT license](#). Use the following commands to download and install this library.

```
pip3 install adafruit-circuitpython-ads1x15
```

The code sample we provide can be downloaded [here](#) or you can run the following command in your console.

```
wget https://www.joy-it.net/files/files/Produkte/COM-MIC-ADMP401/COM-MIC-RPi.zip
```

Now, unpack the file with the following command:

```
unzip COM-MIC-RPi.zip
```

You can now execute the script with the following command. Be aware that your file path may be differ.

```
python3 COM-MIC-RPi.py
```

Alternatively, you can copy the code example here and paste it into your Python file.

```
#!/usr/bin/python
# coding=utf-8
import time
import board
import busio
import adafruit_ads1x15.ads1115 as ADS
from adafruit_ads1x15.analog_in import AnalogIn

# Create the I2C bus
i2c = busio.I2C(board.SCL, board.SDA)

# Create the ADC object using the I2C bus
ads = ADS.ADS1115(i2c)

# Create single-ended input on channel0
chan0 = AnalogIn(ads, ADS.P0)

while True:

    print("channel 0: ", "{:>5}\t{:>5.3f}".format(chan0.value, chan0.voltage))
    time.sleep(1)
```

3. USAGE WITH THE ARDUINO

3.1 Connection

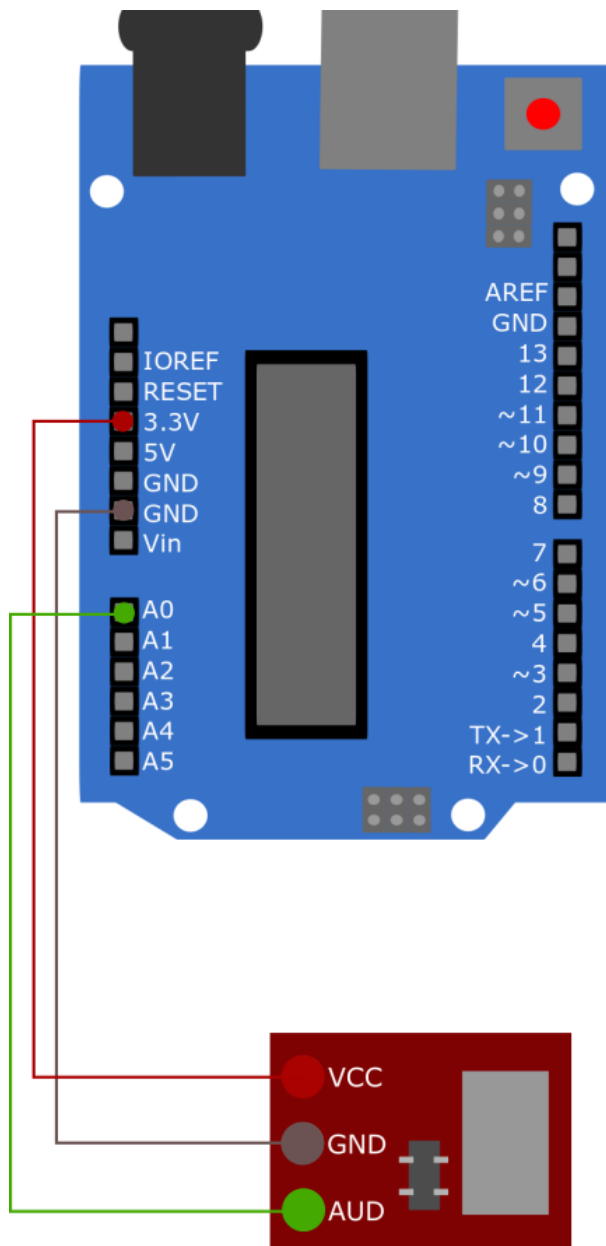

Arduino	ADMP401
3.3V	VCC
GND	GND
A0	AUD

3.2 Code example

Now, copy the following code into your Arduino IDE.

```
int pin = A0;
int value;

void setup() {
    // put your setup code here, to run once:
    Serial.begin(9600);
}

void loop() {
    // put your main code here, to run repeatedly:
    value = analogRead(pin);
    Serial.println(value);
}
```

Click on **Upload** to run the program. However, make sure that **Board** and **Port** are selected correctly under **Tools**. Under **Tools**, click on **Serial Plotter** to display the read-out values of the microphone graphically.

4. OTHER INFORMATION

Our Information and Take-back Obligations according to the Electrical and Electronic Equipment Act (ElektroG)



Symbol on Electrical and Electronic Products:

This crossed-out bin means that electrical and electronic products do not belong into the household waste. You must hand over your old appliance to a registration place. Before you can hand over the old appliance, you must remove used batteries and replacement batteries which are not enclosed by the device.

Return Options:

As the end user, you can hand over your old appliance (which has essentially the same functions as the new one bought with us) free of charge for disposal with the purchase of a new device. Small devices, which do not have outer dimensions bigger than 25 cm can be handed in for disposal independently of the purchase of a new product in normal household quantities.

1. Possibility of return at our company location during our opening hours

Simac Electronics GmbH, Pascalstr. 8, D-47506 Neukirchen-Vluyn

2. Possibility of return nearby

We will send you a parcel stamp with which you can send us your old appliance free of charge. For this possibility, please contact us via e-mail at service@joy-it.net or via telephone.

Information about Package:

Please package your old appliance safe for transport. Should you not have suitable packaging material or you do not want to use your own material, you can contact us and we will send you an appropriate package.

5. SUPPORT

If any questions remained open or problems may arise after your purchase, we are available by e-mail, telephone and ticket support system to answer these.

E-Mail: service@joy-it.net

Ticket-system: <https://support.joy-it.net>

Telephone: +49 (0)2845 9360 – 50 (Mon - Thur: 09:00 - 17:00 o'clock CET, Fri: 09:00 - 14:30 o'clock CET)

For further information visit our website:

www.joy-it.net