

NEMA17-01

42STH47-1684A Stepper Motor

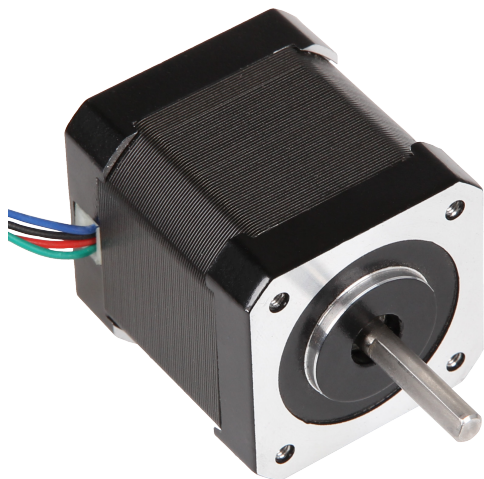

The NEMA17-01 stepper motor can be optimally used for tasks in the areas of automation, CNC (f.e. engraving lasers, 3D printers, milling machines, etc.) or robotic.

KEY FEATURES

Shaft diameter	5mm (Single shaft)
Specification	42STH47-1684A
Connection	4 jumper cables
Steps per revolution	200
Dimensions	42,3 x 42,3 x 47mm
Scope of delivery	NEMA17-01 Motor

PERFORMANCE CHARACTERISTICS

Holding Torque	43.1 Ncm
Rated Voltage	2.8V
Rated Current	1.68A
Step Angle	1.8°
Amount of Phases	2
Temperature Range	-20°C - +50°C
Wiring	Coil 1A: Green Coil 1B: Black Coil 2A: Blue Coil 2B: Red

ADDITIONAL INFORMATION

Article No.	NEMA17-01
EAN	4250236815473
Duty No.	8501101090

SCHEMATIC DIAGRAM

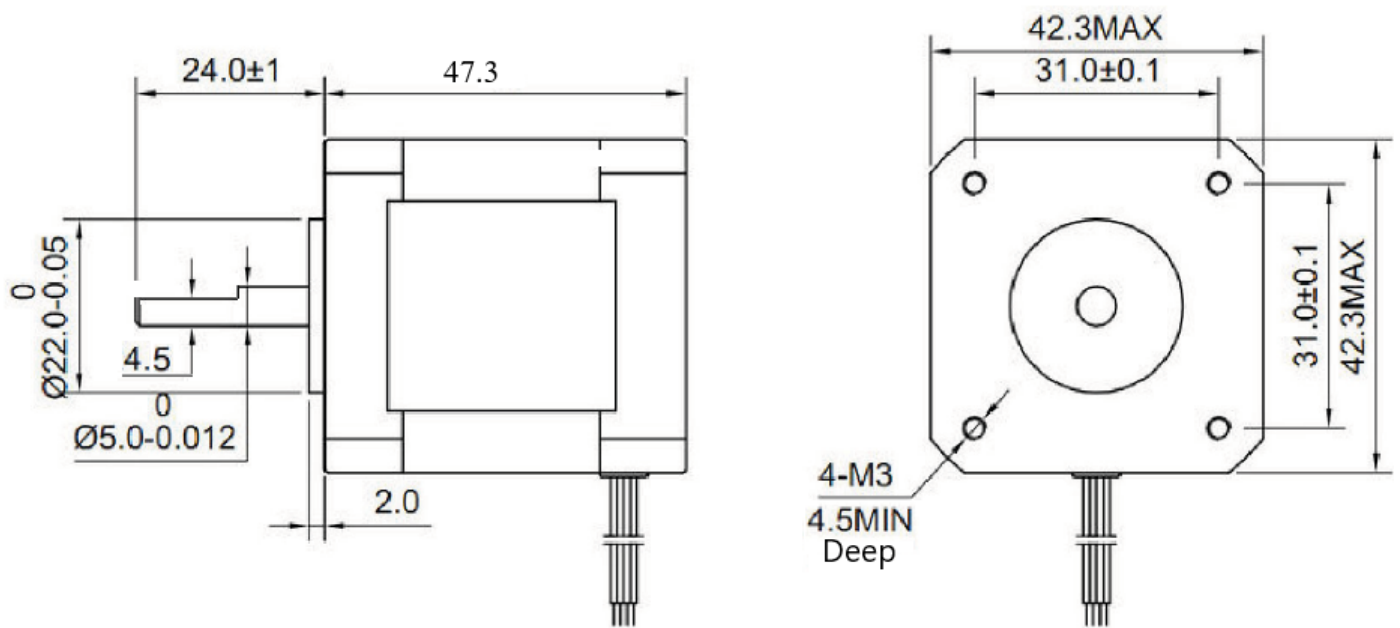

WIRING DIAGRAM

